

RIV938 Hydropneumatic tool for rivet nuts from M3 to M10



1 PHASE TRIGGER
FORCE
ADJUSTMENT

Code 4143400

To place RIVSERT female rivet nuts from M3 to M10 and RIVBOLT male rivet nuts from M4 to M10.

RIV938 to place rivet nuts using force adjustment. Automatic screwing by positioning the tie rod in the rivet nut, 1 PHASE rivet nut deformation and unscrewing.

In order to avoid the use of a special rod, a system has been designed to lodge an allen screw (hardness class 12.9), easy to find on the market and replace.

Advantages: kit assembling without use of the key | does not require any regulation with the change in thickness | no damage to the screw if the operation of deformation of the rivet nut is repeated.

Spare parts for RIVSERT



Ø rivet nut	Kit	Kit code	* Screw code (DIN912 12.9)
M3	938/03	3441100	3457600
M4	938/04	3441200	3470500
M5	938/05	3441300	3471900
M6	938/06	3441400	3472300
M8	938/08	3441500	3472800
M10	938/10	3441600	3473100

* Screw is included in the "Kit code" and can be ordered separately.

Spare parts for RIVBOLT



Ø rivet nut	Kit	Kit code	* Code (female tie rod)
M4	938/04B	3442300	3441900
M5	938/05B	3442400	3442000
M6	938/06B	3442500	3442100
M8	938/08B	3442600	3442200
M10	938/10B	4601900	4601800

* The female tie rod is included in the "Kit code" and can be ordered separately.

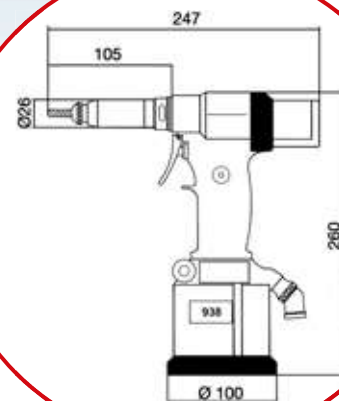

RIV938 is supplied in a case without the frontal head kit. Choose the correct kit according to the size of the rivet nut to be placed, and add it to the order (see the spare parts for RIVSERT/RIVBOLT).

Technical data and features

Air working pressure	6 bar
Min-max air pressure	5/7 bar
Air consumption per cycle (6 bar)	5 lt
Stroke	6.5 mm
Max power (6 bar)	20000 N
Weight (without kit)	2.041 Kg
Vibrations	< 2,5 m/s²
Noise level	76 dB (A)

Force
adjustment.



Optional

Description	Code
KIT938-Special extended head	3531800
Anti-scratch wing protection	4217600

