

# KEENSERTS®

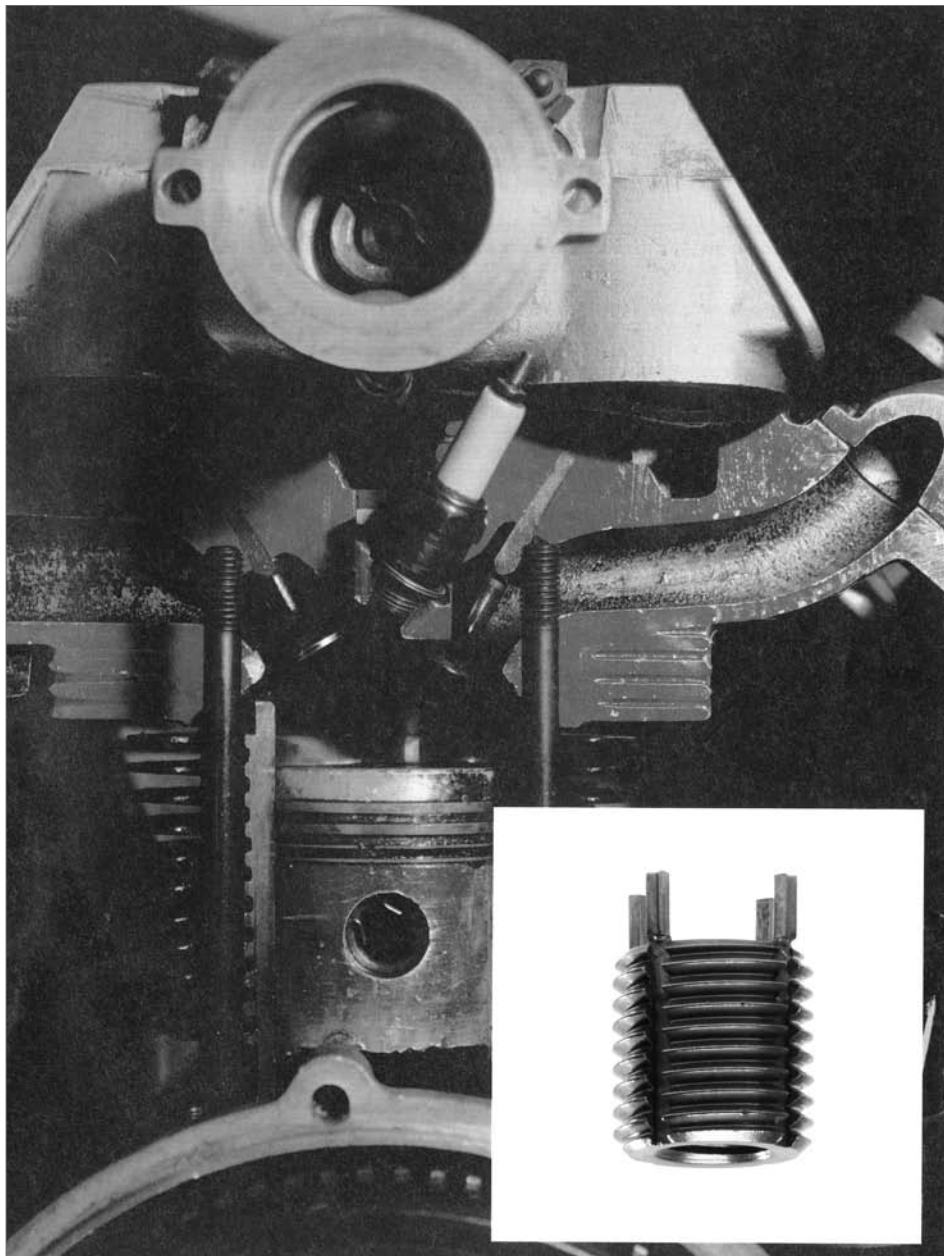

	Page
General Information .....	A-2
Important Information <b>KEENSERTS</b> ® .....	A-3
General Installation Instructions.....	A-4
KNCMSeries.....	B-1
KNMSeries.....	B-2
KNHMSeries.....	B-3-B-4



The Camloc brand was established in 1937. Since that time our fastening systems have been successfully integrated into numerous applications within many different industries.

Each of our customers will feel the full benefit of our 70 years of fastening experience.

Customer proximity, environmental awareness and quality are the main criteria of our services and products.



**ISO/TS 16949: 2002**



**DIN EN ISO 14001 : 2005**

Please find additional information about our environmental program under: [www.alcoa.com](http://www.alcoa.com).

Your Alcoa Fastening Systems team

**Disclaimer:**

Parts listed are subject to technical changes. All dimensions in mm. All information is correct to the best of our knowledge at the time of printing. No liability for disadvantages caused by printing errors or false application.

## Threaded Inserts

**KEENSERTS®** are high strength threaded inserts made from stainless steel 1.4305. They are passivated according to EN 2516. Our **KEENSERTS®** standard product range contains metric thread dimensions. Imperial dimensions and specials are available upon request.

**KEENSERTS®** may be used in alloys, light materials, steel and cast iron to increase the strength of the thread in these materials. They can also be used for thread repair, whereas the defect thread can be replaced with the same nominal diameter.

**KEENSERTS®** have less attrition. A multiple tightening and loosening of the bolt is possible. Locking inserts include a dry film lubrication on the surface to protect the screw from galling.

**KEENSERTS®** have a positive lock against rotation and vibration.

**KEENSERTS®** have 2 or 4 pre-assembled kees depending on diameter. After installation of the kees into the parent material the assembly is form-closed. No check with a thread gauge according to DIN standard possible in the area of the kees.

Pull-out-strength for **KEENSERTS®**. Calculation as follows:

Pull-out-strength(N) = shear engagement (mm<sup>2</sup>) x ultimate shear strength of parent material (N/mm<sup>2</sup>)  
Data for shear engagement see installation data.

### Part-no. example:

The part-no. for metric **KEENSERTS®** are coded as follows:

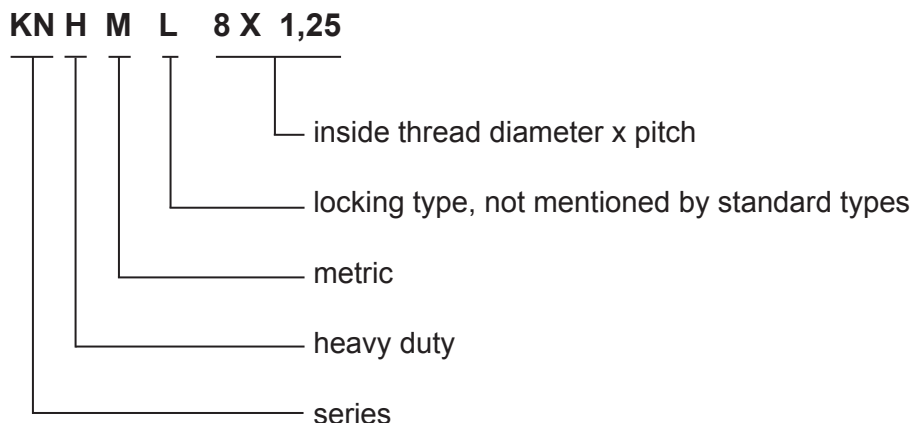

## Installation:

- Drilling - with standard drill
- Countersink - with cone countersink (80° - 100°)
- Threading - with standard tap
- Screw in - by hand or with installation tool  
(see installation data pages B-1 to B-4)
- Locking - installation of the kees with installation tool and hammer (see picture) or press

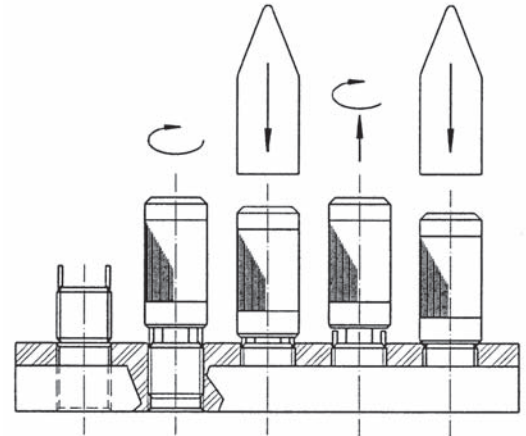

Installation depth of the insert is defined by the pre-assembled kees.  
The thread depth of the **KEENSERTS®** is based on the depth of the countersink.

### Key Slot Pre-Broaching:

For very hard materials with a hardness greater than 30 HRC or 300 Vickers a broaching tool for pre-broaching is necessary.

Threaded inserts, installation as described but before locking the keys in position, mark the key positions, remove insert and pre-broach key slots with broaching tool.



Available for external thread M5 and up.

## Removal:

1. Drilling  
Dimensions see pages B1 to B4
2. Deflect kees inward and break of
3. Remove insert with E-Z OUT type tool
4. Insert new **KEENSERTS®**

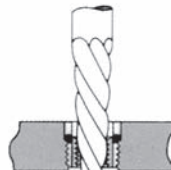
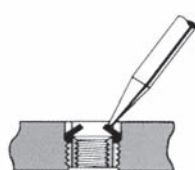
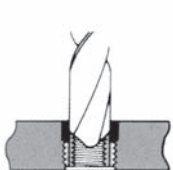

## KNCM Series

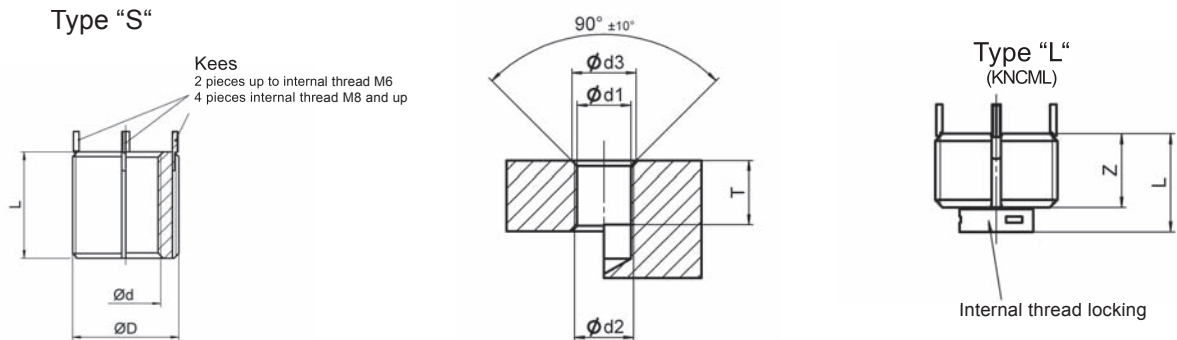

Part-no.		Dimensions				
Standard type "S"	Locking type "L"	Ø d 5H	Ø D 4h	Shear engagement mm <sup>2</sup>	L ± 0,25	Z
KNCM2X0,4		M2	M4	16,5	3	
	KNCML2X0,4			10,3		2,2
KNCM2,5X0,45		M2,5	M4,5X0,75	26,5	3,8	
	KNCML2,5X0,45			15,9		2,7
KNCM3X0,5		M3	M5	33,1	4,25	
	KNCML3X0,5			21,4		3,1
KNCM4X0,7		M4	M6X0,75	58,4	5,25	
	KNCML4X0,7			42,9		4,1

Part-no.	Installation dimensions				Hand installation tool part-no.	Removal dimensions	
	d1 Tap drill- Ø	d3 Counter- sink Ø	Thread			Drill	
			Ø d2 6H	T min.		Ø	Depth
KNCM2X0,4	3,4	4,1	M4	4,0	KRTM2-01	2,8	2,00
KNCML2X0,4							
KNCM2,5X0,45	3,9	4,6	M4,5X0,75	5,0	KRTM2,5-01	3,0	2,00
KNCML2,5X0,45							
KNCM3X0,5	4,4	5,1	M5	5,5	KRTM3-01	3,5	2,25
KNCML3X0,5							
KNCM4X0,7	5,5	6,1	M6X0,75	6,5	KRTM4-01	4,6	2,50
KNCML4X0,7							

## KNM Series

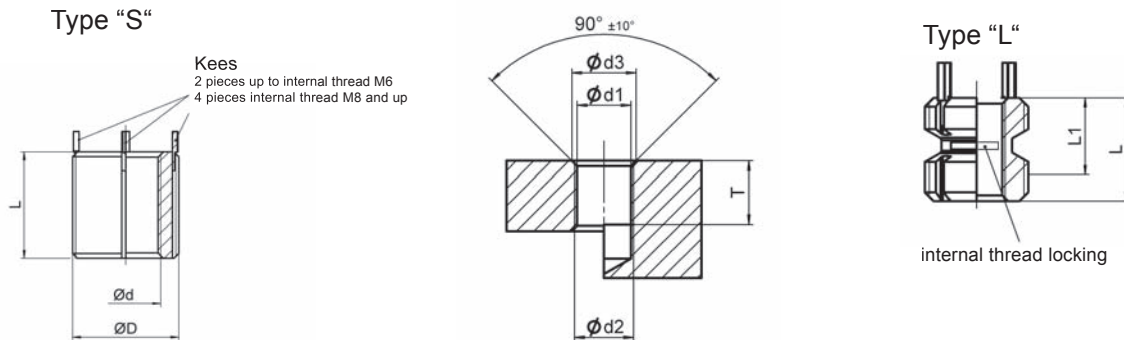

Part-no.		Dimensions				
Standard type "S"	Locking type "L"	Ø d 5H	Ø D 4h	Shear engagement mm <sup>2</sup>	L ± 0,25	Z
KNM5X0,8		M5	M8	104,9	8	7,6
	KNML5X0,8			83,1		
KNM6X1,0		M6	M10X1,25	177,7	10	8,2
	KNML6X1,0			152,7		
KNM8X1,25		M8	M12X1,25	266,7	12	9,5
	KNML8X1,25			242,7		
KNM10X1,5		M10	M14X1,5	341,6	14	10,0
	KNML10X1,5			316,4		
KNM12X1,75		M12	M16X1,5	470,2	16	11,2
	KNML12X1,75			441,4		

Part-no.	Installation dimensions				Hand installation tool part-no.	Removal dimensions	
	d1 Tap drill-Ø	d3 Counter-sink Ø	Thread			Drill	
			Ø d2 6H	T min.		Ø	Depth
KNM5X0,8	6,90	8,25	M8	9,5	KRTM5-01	5,5	4,00
KNML5X0,8							
KNM6X1,0	8,80	10,25	M10X1,25	11,5	KRTM6-01	7,5	4,75
KNML6X1,0							
KNM8X1,25	10,80	12,25	M12X1,25	13,5	KRTM8-01	9,5	4,75
KNML8X1,25							
KNM10X1,5	12,80	14,25	M14X1,5	15,5	KRTM10-01	11,5	4,75
KNML10X1,5							
KNM12X1,75	14,75	16,25	M16X1,5	17,5	KRTM12-01	13,5	4,75
KNML12X1,75							



## KNHM Series

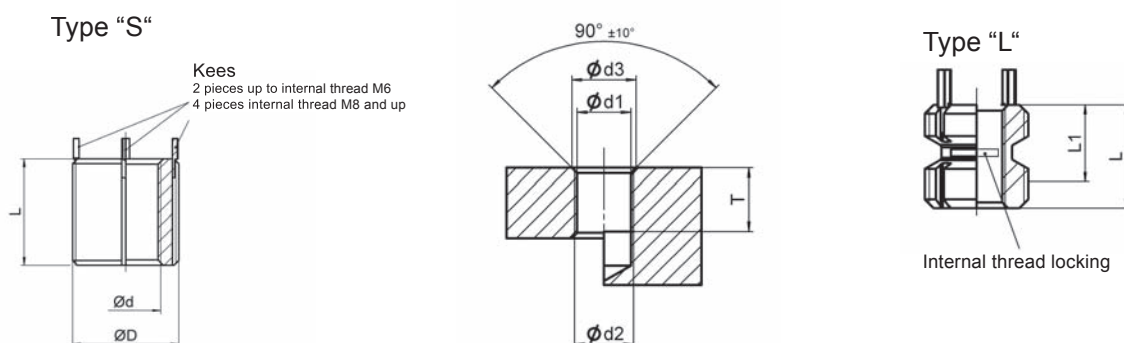

Part-no.		Dimensions				
Standard type "S"	Locking type "L"	Ø d 5H	Ø D 4h	Shear engagement mm <sup>2</sup>	L ± 0,25	Z
KNHM4X0,7		M4	M8	104,9	8	8,0
	KNHML4X0,7			83,1		
KNHM5X0,8		M5	M10X1,25	177,1	10	8,7
	KNHML5X0,8			152,7		
KNHM6X1,0		M6	M12X1,25	266,7	12	9,5
	KNHML6X1,0			242,5		
KNHM8X1,25		M8	M14X1,5	341,6	14	10,0
	KNHML8X1,25			316,4		
KNHM10X1,5		M10	M16X1,5	470,2	16	10,0
	KNHML10X1,5			441,4		
KNHM12X1,75		M12	M18X1,5	608,5	18	10,7
	KNHML12X1,75			561,8		

Part-no.	Installation dimensions				Hand installation tool part-no.	Removal dimensions	
	d1 Tap drill-Ø	d3 Counter-sink Ø	Thread			Drill	
			Ø d2 6H	T min.		Ø	Depth
KNHM4X0,7	6,90	8,25	M8	9,5	KRTM4-02	5,5	4,00
KNHML4X0,7							
KNHM5X0,8	8,80	10,25	M10X1,25	11,5	KRTM5-02	7,5	4,75
KNHML5X0,8							
KNHM6X1,0	10,80	12,25	M12X1,25	13,5	KRTM6-02	9,5	4,75
KNHML6X1,0							
KNHM8X1,25	12,80	14,25	M14X1,5	15,5	KRTM8-02	11,5	4,75
KNHML8X1,25							
KNHM10X1,5	14,80	16,25	M16X1,5	17,5	KRTM10-02	13,5	4,75
KNHML10X1,5							
KNHM12X1,75	12,80	12,80	M18X1,5	19,5	KRTM12-02	15,5	4,75
KNHML12X1,75							



## KNHM Series

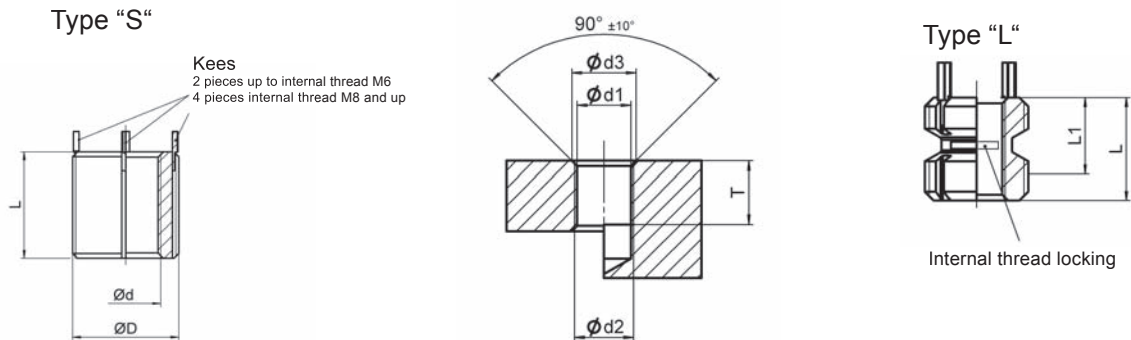

Part-no.		Dimensions				
Standard type "S"	Locking type "L"	Ø d 5H	Ø D 4h	Shear engagement mm <sup>2</sup>	L ± 0,25	Z
KNHM14X2,0		M14	M20X1,5	770,5	20	12,4
	KNHML14X2,0			724,4		
KNHM16X2,0		M16	M22X1,5	896,8	22	12,4
	KNHML16X2,0			855,2		
KNHM18X1,5		M18X1,5	M24X1,5	1084,4	24	16,8
	KNHML18X1,5			1051,5		
KNHM20X2,5		M20	M30X2,0	1774,3	30	17,5
	KNHML20X2,5			1736,4		
KNHM24X3,0		M24	M33X2,0	2189,4	33	19,0
	KNHML24X3,0			2161,9		

Part-no.	Installation dimensions				Hand installation tool part-no.	Removal dimensions	
	d1 Tap drill-Ø	d3 Counter-sink Ø	Thread			Drill	
			Ø d2 6H	T min.		Ø	Depth
KNHM14X2,0	18,75	20,25	M20X1,5	22,5	KRTM14-02	17,50	4,75
KNHML14X2,0							
KNHM16X2,0	20,50	22,25	M22X1,5	24,5	KRTM16-02	17,75	4,75
KNHML16X2,0							
KNHM18X1,5	22,50	24,25	M24X1,5	26,5	KRTM18-02	19,75	4,75
KNHML18X1,5							
KNHM20X2,5	28,00	30,25	M30X2,0	34,5	KRTM20-02	25,75	6,35
KNHML20X2,5							
KNHM24X3,0	31,00	33,25	M33X2,0	37,5	THM24	28,75	6,35
KNHML24X3,0							